



F3 RE 15 AB F3 RE 20 AB

RETRACTABLE TAIL-LIFTS FOR LOW DRAWBAR COUPLING

LOAD CAPACITY: 1500, 2000 KG



DESCRIPTION

F3 RE 15/20 AB with Chromed Guides, premium quality, perfect alignment, low maintenance for demanding applications in the high volume transport business, such as supermarket and flowers distribution, is especially designed for trucks equipped with low coupling drawbar trailer.

Retraction system with chromed guides, smooth hydraulic automatic tilt, high stiffness ideal to equip vehicles for customers that like high performances with lower maintenance costs.

SPECIFICATIONS

Platform:	Aluminium
Platform depth:	from 1600 to 1800 mm rear bumper EEC type approved
Lift cylinders:	2
Tilt cylinders:	2
Autotilt at ground:	hydraulic (with memory feature)
Sliding system:	Chromed steel guides with push-pull cylinder
Power supply:	12 or 24 V
Low maint. bushes:	greasable
Frame color:	Black KTL plus and powder paint
Weight:	from 580 Kg

SUGGESTED OPTIONS

- Inside body remote control;
- Radio remote control;
- Foot operated controls on platform;
- Blinking lights on platform;
- Roll stop;
- Torsion bar





F3 RE 15 AB F3 RE 20 AB

RETRACTABLE TAIL-LIFTS FOR LOW DRAWBAR COUPLING

LOAD CAPACITY: 1500, 2000 KG

TECHNICAL DATA

1 FOLD PLATFORM	Mod.	Load capacity (centre of gravity at 600 mm)	Floor to ground (max)	Platform Depth* (example)	Mounting space (min)	Weight* Kg
	F3 RE 15 HS AB	1500 Kg	1410	1583 (550+1033)	1785	580
				1783 (750+1033)	1985	615
	F3 RE 20 HS AB	2000 Kg	1410	1633 (600+1033)	1835	605
1783 (750+1033)				1985	640	

01/2021

2 FOLDS PLATFORM	Mod.	Load capacity (centre of gravity at 600 mm)	Floor to ground (max)	Platform Depth*	Mounting space (min)	Weight* Kg
	F3 RE 15 HS AB	1500 Kg	1410	1583 (850+733)	1315	610
	F3 RE 20 HS AB	2000 Kg	1410	1583 (850+733)	1315	630

*Approximate weight for tail-lift equipped with aluminium platform 2450 mm wide.

The above mentioned weights are approximate and may vary according to production. Anteo reserves the right to change weights and technical specifications without prior notice. No indemnity for damages can be claimed from Anteo for changes in technical specifications and/or in weight.

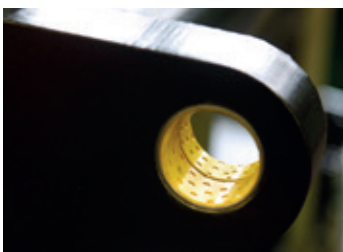
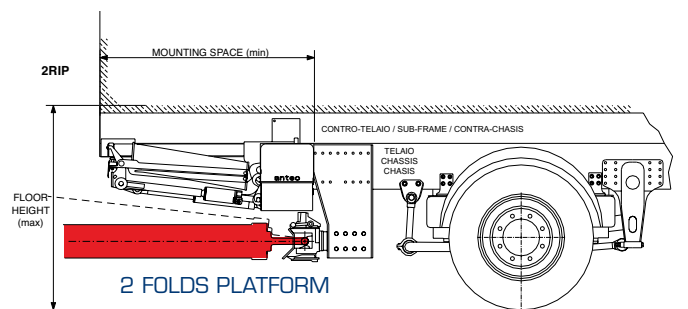
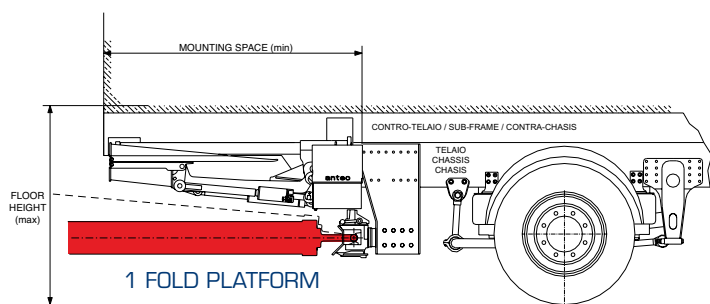

LOW MAINTENANCE BUSHES AND CHROMIUM PLATED PINS.



POWDER COATING PAINT (2) ADDED TO KTL PLUS (1). NO RUST AND NO SALT STAINS.

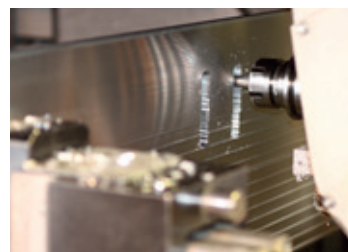

HI-TENSILE ALUMINUM SPECIALISTS SINCE 1992.



LOW NOISE POWER UNIT & NO ELECTRONICS = EASY MAINTENANCE