



F3 DD-G

DOUBLE-DECK COLUMN LIFTS

LOAD CAPACITY: 1000, 1500, 2000 KG



DESCRIPTION

The F3 DD 10-15-20 G is a column lift. It is a lift to access multiple loading floors and can be used for special applications and it's suitable for distribution of bulk goods.

It is manufactured with a chain system operated by two lift cylinders. The chains, aided by two safety steel ropes, are built to perform effectively even in the most severe operating conditions.

Tail-lift is always built according to customer's request.

SPECIFICATIONS

Platform depth:	2600 mm
Platform width:	related to width over columns
Lift cylinders:	2
Tilt cylinders:	2
Autotilt at ground:	none - level ride
Platform opening:	Gravity opening
Power supply:	24 V
Frame color:	Black KTL
Weight:	from 900 Kg

SUGGESTED OPTIONS

- Inside body remote control;
- Radio remote control;
- Foot controls on platform
- Side loading ramps;
- Roll-stop





F3 DD-G

DOUBLE-DECK COLUMN LIFTS

LOAD CAPACITY: 1000, 1500, 2000 KG

TECHNICAL DATA

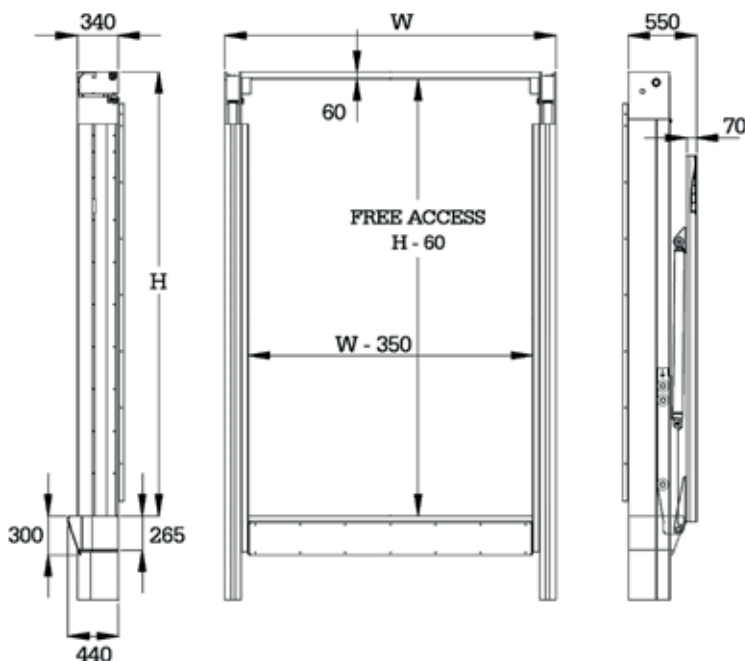
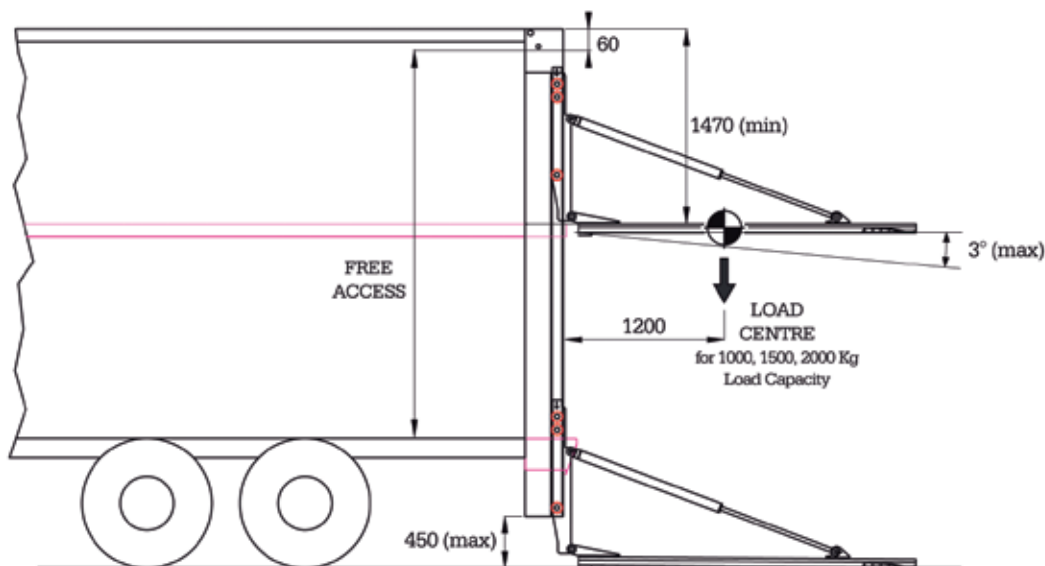

01/2021