



F3 MH 075 F3 MHX 075

CANTILEVER TAIL-LIFTS WITH HALF PLATFORM

LOAD CAPACITY: 750 KG



DESCRIPTION

The 2-cylinder F3 MH 075 - F3 MHX 075 - with Half platform are light compact lifts with high simplicity, low maintenance cost and attractive pricing ideal to equip rental vehicles and light duty commercial vehicles.

These half platforms keep one of the rear doors of the vehicle body free, offering quick and unobstructed access to the cargo space at all times. The F3 MH 075 and F3 MH X 075 suit most commercial vehicles and light trucks up to 7.5T GVW.

- ALUMINUM** REAR BUMPER BAR up to 3,5T GVW
- STEEL** REAR BUMPER BAR up to 6,5T GVW

SPECIFICATIONS

Platform width:	On demand
Platform depth:	1400 to 1800 mm
Lift cylinders:	1
Tilt cylinders:	1
Autotilt at ground:	Mechanic
Platform opening:	Gravity opening
Power supply:	12 or 24 V
Frame color:	Black KTL plus and powder paint
Weight:	from 175 Kg

SUGGESTED OPTIONS

- Inside body remote control;
- Radio remote control;
- Foot operated controls on platform;
- Blinking lights on platform;
- Roll stop;
- Locking handle





F3 MH 075 F3 MHX 075

CANTILEVER TAIL-LIFTS WITH HALF PLATFORM

LOAD CAPACITY: 750 KG

TECHNICAL DATA

Mod.	Load Capacity (600 mm load centre)	Standard platform dimension		Weight* (Kg)	Floor to ground (max)	Floor to bottom of chassis		Mounting space	
		Depth	Width			min	max	min	max
F3 MH 075 C	750 Kg	1200 1400 1600 1800	on demand	175	1020	270	440	570	598
F3 MH 075 H				205	1180	330	530	710	810
F3 MHX 075 C				175	1020	270	440	570	598
F3 MHX 075 H				205	1180	330	530	710	810

*Approximate weight for tail-lift equipped with aluminium platform dimensions 1400 x 900 mm.

The above mentioned weights are approximate and may vary according to production. Anteo reserves the right to change weights and technical specifications without prior notice. No indemnity for damages can be claimed from Anteo for changes in technical specifications and/or in weight.

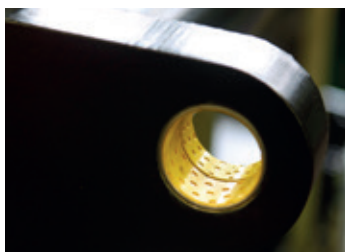
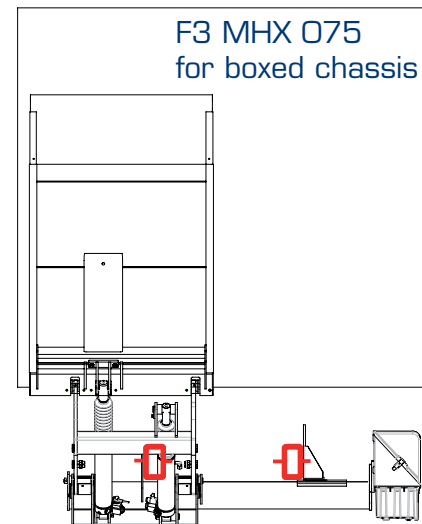
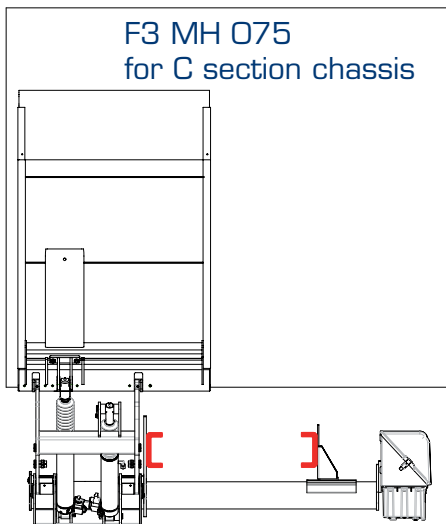

LOW MAINTENANCE BUSHES
AND CHROMIUM PLATED PINS.



POWDER COATING PAINT (2)
ADDED TO KTL PLUS (1). NO
RUST AND NO SALT STAINS.

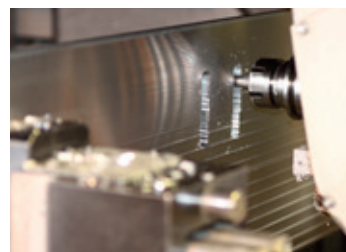

HI-TENSILE ALUMINUM
SPECIALISTS SINCE 1992.



LOW NOISE POWER UNIT
& NO ELECTRONICS = EASY
MAINTENANCE

01/2021