



F3 RE 15 LR F3 RE 20 LR

**RETRACTABLE LEVEL-RIDE
WITH ALUMINIUM GUIDES**

LOAD CAPACITY: 1500, 2000 KG



DESCRIPTION

F3 RE 15/20 LR is especially suited to Roll Cage operations, but more specifically to the typical British food industry operator.

Anteo superb guide rail system eliminates any 'Racking or Bounce' of the lift frame and platform during deployment and retraction.

Available with tilt cylinders to set the platform at any level, a must where the operator loads or unloads on gradients (option).

SPECIFICATIONS

Platform:	Aluminum (1 piece) Steel+Aluminum (single fold)
Platform depth:	from 1300 to 1900 mm rear bumper EEC type approved
Lift cylinders:	2
Tilt cylinders:	2 (option)
Autotilt at ground:	none - levelride
Sliding system:	Alloy guides and hydraulic motor
Power supply:	12 or 24 V
Low maint. bushes:	greasable
Frame color:	Black KTL plus and powder paint
Weight:	from 502 Kg

SUGGESTED OPTIONS

- Inside body remote control;
- Radio remote control;
- Foot operated controls on platform;
- Tilt cylinders;
- Front ramps;
- Side ramps





F3 RE 15 LR F3 RE 20 LR

RETRACTABLE LEVEL-RIDE WITH ALUMINIUM GUIDES

LOAD CAPACITY: 1500, 2000 KG

TECHNICAL DATA

Mod.	Load capacity (centre of gravity at 600 mm)	1 Fold platform (steel + aluminum)					1 Piece platform	
		Total depth (V)	H	Z	Z	Mounting space	Total depth (V)	Mounting space
F3 RE 15 LR	1500 Kg	1516	616	900	920	1583	1300	2256
F3 RE 20 LR	2000 Kg	1716	716	1000	1020	1683	1500	2456
		1916	816	1100	1120	1783	1800	2756

All dimension in mm unless otherwise specified. Anteo reserves the right to change weights and technical specifications without prior notice. No indemnity for damages can be claimed from Anteo for changes in technical specifications and/or in weight.

01/2021

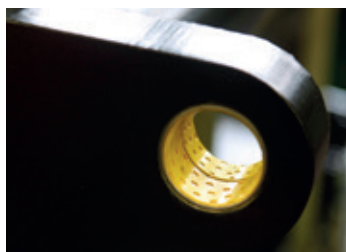
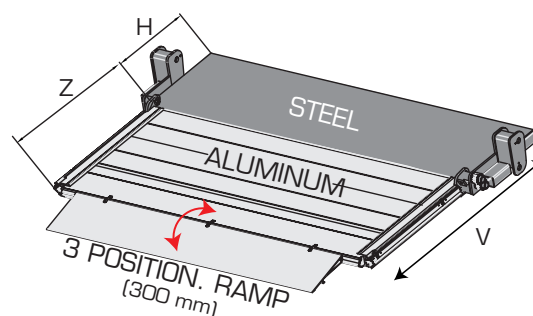
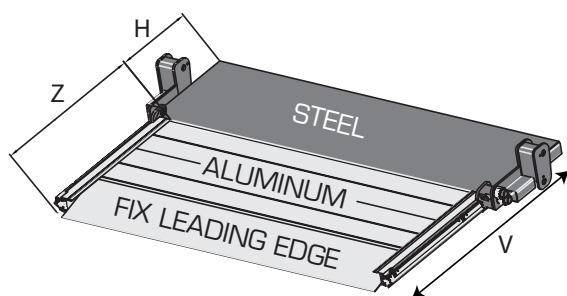

LOW MAINTENANCE BUSHES AND CHROMIUM PLATED PINS.



POWDER COATING PAINT (2) ADDED TO KTL PLUS (1). NO RUST AND NO SALT STAINS.

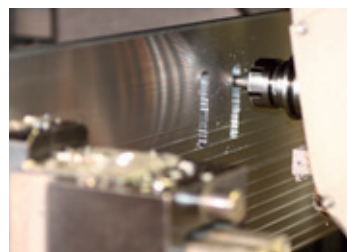

HI-TENSILE ALUMINUM SPECIALISTS SINCE 1992.



LOW NOISE POWER UNIT & NO ELECTRONICS = EASY MAINTENANCE