



**F3 V 050 F**  
**F3 V 075 F**

## TAIL-LIFT FOR PANEL VANS

LOAD CAPACITY: 500, 750 KG



### DESCRIPTION

The F3 V 050 F / F3 V 075 F has been designed and built for the 3.5 / 5 ton panel van range and can be installed easily without modifications to the host vehicle.

Installation is made quick and easy with individual mounting brackets to suit most commercial vans such as:

- Fiat DUCATO - Citroen JUMPER - Peugeot BOXER
- Ford TRANSIT
- Iveco DAILY
- Mercedes Benz SPRINTER
- Renault MASTER - Opel MOVANO
- Volkswagen CRAFTER - Man TGE

Towing hook preparation available on demand.

### SPECIFICATIONS

Platform width:	700 mm 700+700 mm foldable 1400 mm single piece
Platform depth:	1400 or 1600 mm
Lift cylinders:	1
Tilt cylinders:	1
Autotilt at ground:	Hydraulic (with memory feature)
Platform opening:	Hydraulic opening
Power supply:	12 V
Frame color:	Black KTL plus and powder paint
Weight:	from 177 Kg

### SUGGESTED OPTIONS

- Inside body remote control;
- Radio remote control;
- Foot operated controls on platform;
- Blinking lights on platform;
- Roll stop;
- Bridge plate to van floor





# F3 V 050 F F3 V 075 F

## TAIL-LIFT FOR PANEL VANS

LOAD CAPACITY: 500, 750 KG

### TECHNICAL DATA

Mod.	Load Capacity (600 mm load centre)	Standard platform dimension		Weight* (Kg)	Floor to ground (max)
		Depth	Width		
F3 V 050 F	500 Kg	1400	700 mm (single piece)	143	800
F3 V 075 F	750 Kg	1600	700+700 mm (folded)	179	
		1800	1400 mm (single piece)	177	

\* Approximate weight for tail-lift equipped with aluminium platform dimensions 1600 x 700+700 mm.  
The above mentioned weights are approximate and may vary according to production. Anteo reserves the right to change weights and technical specifications without prior notice. No indemnity for damages can be claimed from Anteo for changes in technical specifications and/or in weight.

01/2021

### PLATFORMS ON DEMAND

#### HALF PLATFORM SINGLE PIECE

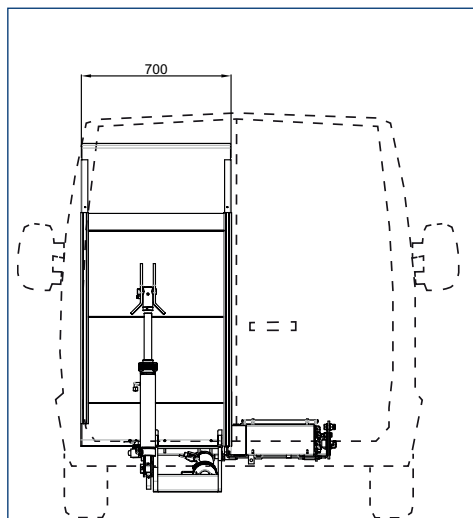

#### FOLDED PLATFORM 2 PIECES

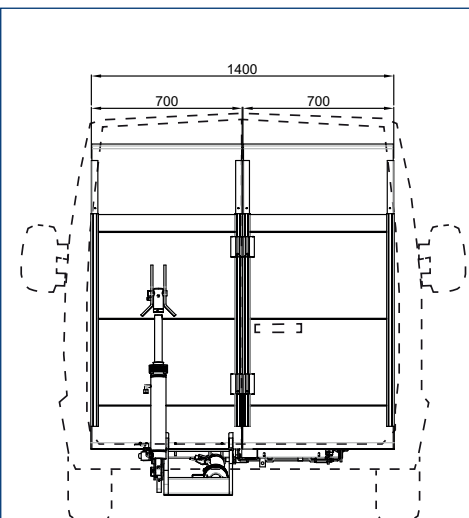

#### WHOLE PLATFORM 1 PIECE

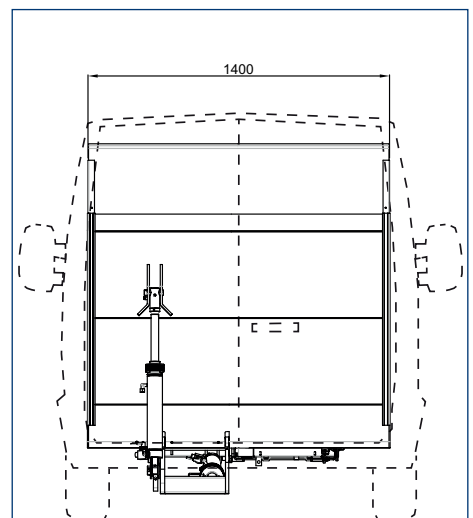

**WHAT'S NEW !**

**ANTI VIBRATION SYSTEM FOR PLATFORM  
(NO NEED OF RUBBER BUFFERS TO THE DOORS)**



**WHAT'S NEW !**

2

**POWDER COATING PAINT (2)  
ADDED TO KTL PLUS (1). NO  
RUST AND NO SALT STAINS.**



**LOW NOISE POWER UNIT  
& NO ELECTRONICS = EASY  
MAINTENANCE**