



ST 600
ST 1100

SIDE DOOR ELECTRIC STEPS

LOAD CAPACITY: 320 KG



DESCRIPTION

ST 600 / ST 1100 is an electric deployment and stowage service step which can be fitted under the side sliding door of the most common passenger vans, such as:

- Citroen JUMPER - RELAY
- Fiat DUCATO
- Ford TOURNEO - TRANSIT
- Iveco DAILY
- Mercedes Benz SPRINTER
- Nissan NV400
- Opel MOVANO - VIVARO
- Peugeot BOXER
- Renault MASTER - TRAFIC
- Volkswagen CRAFTER
- Man TGE

SPECIFICATIONS

- Reduces the distance between the vehicle and the ground.
- Electric deployment and stowage (rotation and translation only st 1100).
- Step light for night use.
- Lever for manual step stowage in emergency.
- Cabin led indicating that the step is in working mode.





ST 600 ST 1100

SIDE DOOR ELECTRIC STEPS

LOAD CAPACITY: 320 KG

TECHNICAL DATA

Model	Load capacity (max)	Voltage	Step dimension		Cassette dimension		Weight
			Width	Depth	Width	Depth	
ST 600	250 Kg	12 Volt	600 mm	330 mm	745 mm	480 mm	23 Kg
ST 1100	300 Kg	12 Volt	1150 mm	265 mm	1160 mm	280 mm	25 Kg

ST 600

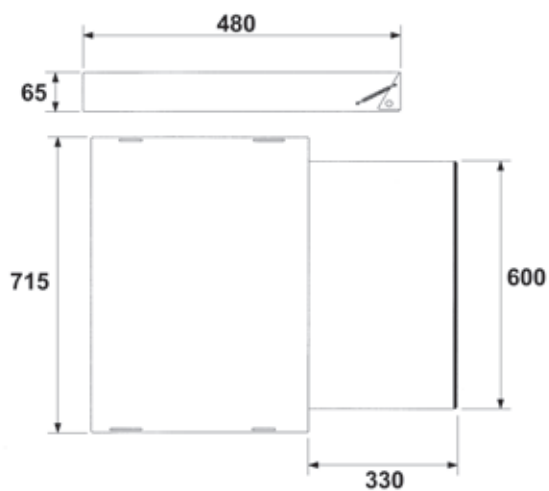

ST 1100

